

### Headrest adjustment:

To adjust the headrest height, lift up the headrest (①) to desired position.

To adjust the headrest angle, turn the headrest directly to desired angle.

### Back height adjustment:

To change the back height (②), lift up the back by pulling up the button (②) at the bottom of the back, then adjust the back height up or down to proper position.

### Armrest adjustment (③):

To adjust the armtop angle, press the button under the top and rotate the armtop to desired position, armtop rotating can be 360 degree.

To rise up or lower down the armrest, press the button on the armrest, hold and move up or down.

To move the arm top position, push the top forward or pull backward.

To adjust the arm width, turn anticlockwise the knob to unlock the arm, pull or push the arm to desired position, then turn clockwise the knob to lock.

### Seat depth adjustment:

To enlarge the seat depth, pull out the slider lever (④) and move frontward to desired position, then release the lever.

To go back to the first position, pull out the slider lever again and remove body weight from the seat.

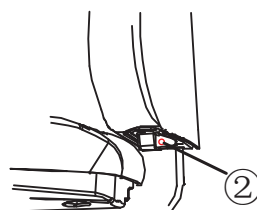
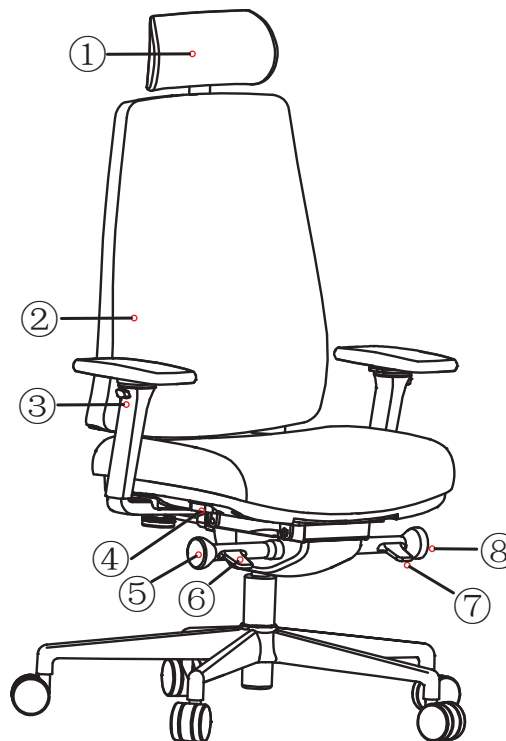

### Tilt tension adjustment:

To adjust the seat tilt tension, turn the tension adjustment

knob (⑤) on the mechanism to desired tension, turn clockwise or anticlockwise.

Clockwise to stronger and anticlockwise to weaker.

### Seat height adjustment:

To raise the seat height, remove weight from the seat and pull up on the height adjustment lever (⑥), release the lever when reaching the desired position.

To lower the seat height, while seated, pull up slowly on the height adjustment lever until the seat is at the desired height.

### Backrest angle adjustment (Swing/Tilt Lock):

To change backrest's position, pull up the adjustment

lever (⑦) to unlock, then lie backwards the backrest to desired position, and push down the adjustment lever to lock.

To go back to the first position, pull up the adjustment lever, lie backwards again and then backrest will return automatically.

### Forward angle adjustment:

To adjust the forward angle, keep the tilt lock lever at the unlock

position, turn clockwise the angle knob (⑧), lie backward the backrest little bit, then when user at a forward working position, the seat and back will follow user's posture.

To go back to normal position, turn anticlockwise the angle knob, then lie back again, then chair body will back to normal position.